

MAGURA

MT

OWNER'S MANUAL

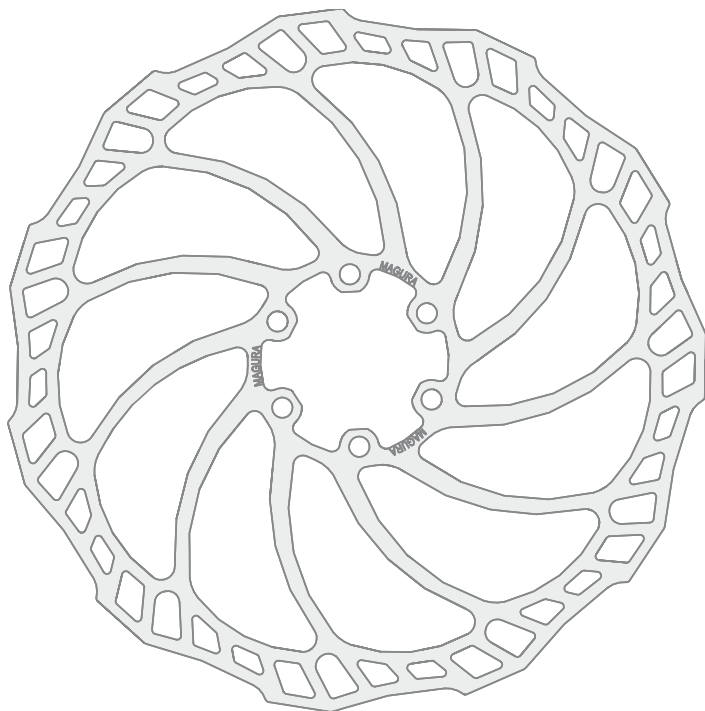

MAGURA

INTRODUCTION

Preface	12
Legend	12

TECHNICAL SPECIFICATIONS

Specifications	13
Dimensions – assembly	13
Combinations – disc brake rotors ..	13

SAFETY

Intended use	14
Basic safety instructions	14

INSTALLATION

Combinations – QM-adapter	16
Installing the brake	16
Installing the adapter	16
Installing brake lever	16
Installing disc brake rotor	17
Installing brake calliper	17
Aligning & laying out the brake hose ..	18
Shortening brake hose	18
Setting the pressure point	20
Adjusting the brake levers	20
HC ³ – adjust braking power	20

ON THE MOVE

Prior to first ride	21
Bedding-in brake pads	21
Before each ride	21
During transport	21

MAINTENANCE

Regular	22
Checking wear on brake pads and disc brake rotors	22
Changing brake pads	23
Bleeding and filling brake	24

THE RULES

Liability	26
Warranty	26

DIAGRAMS

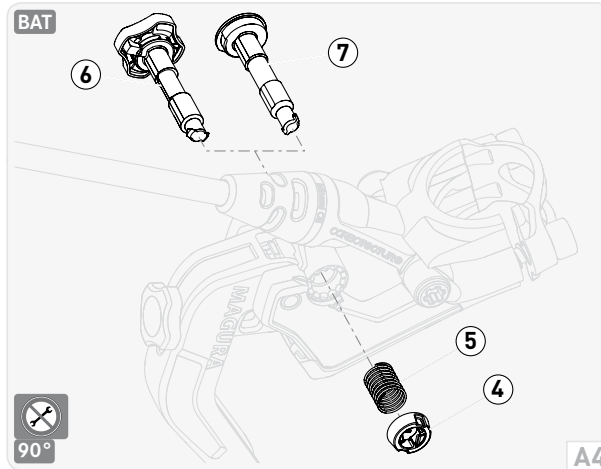
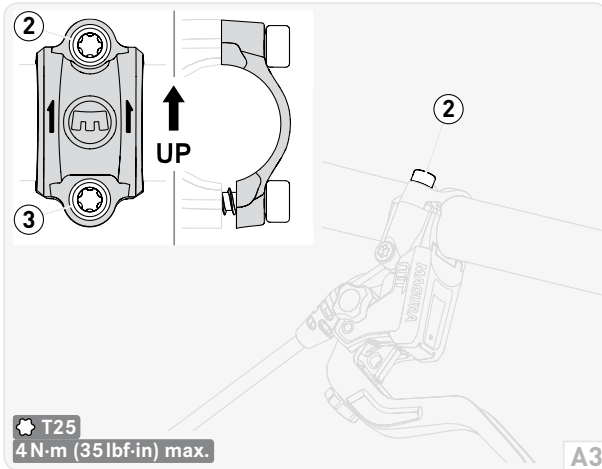
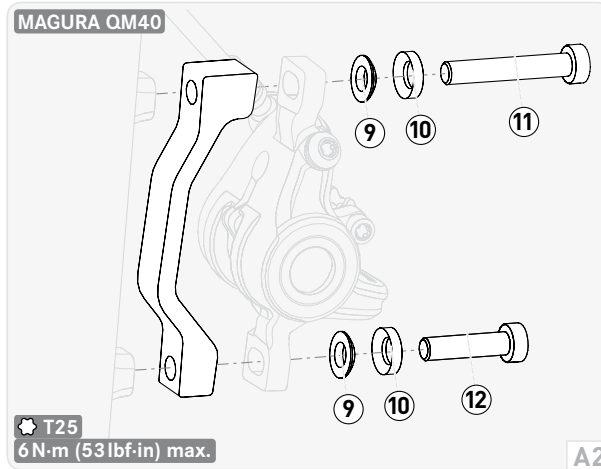
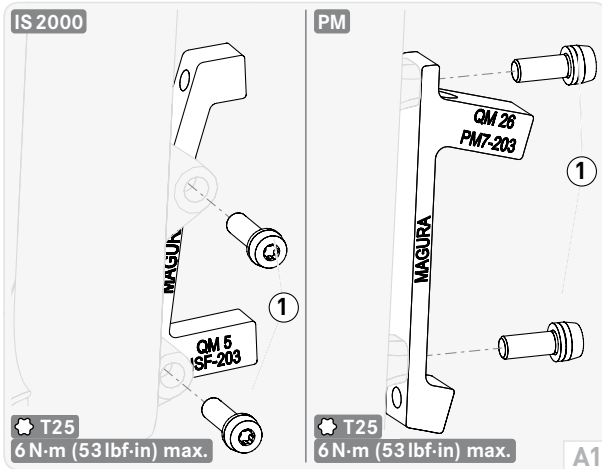

DIAGRAMS

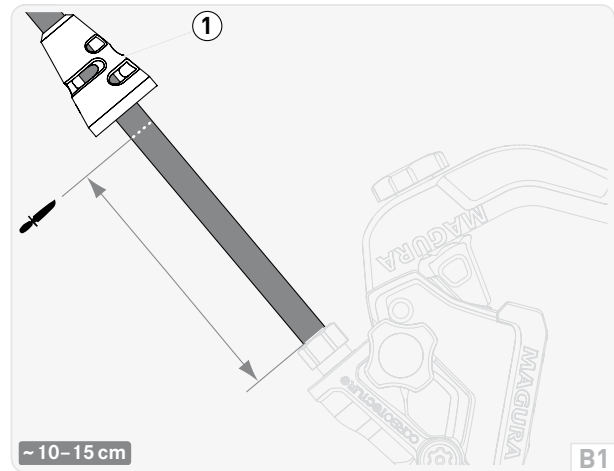
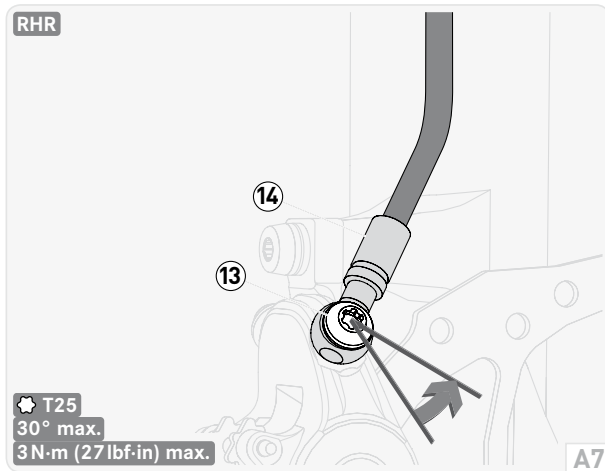
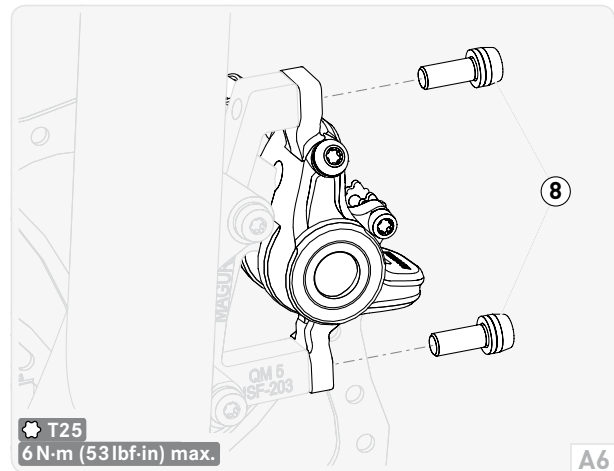
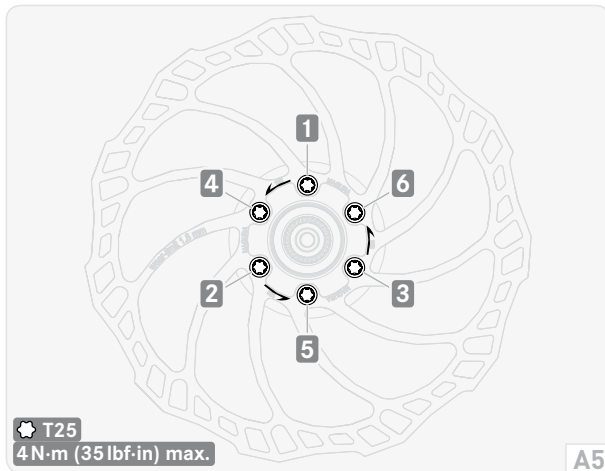

DIAGRAMS

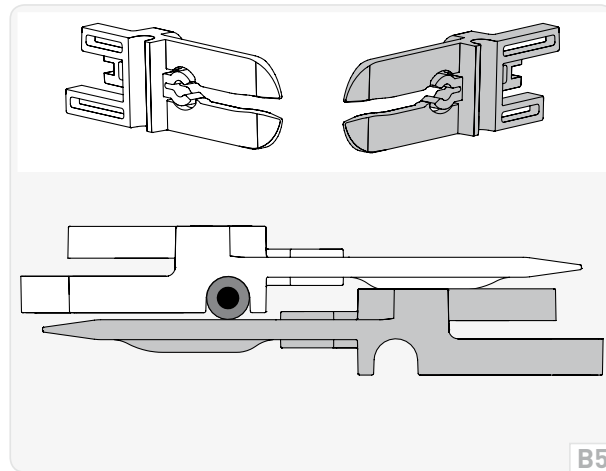
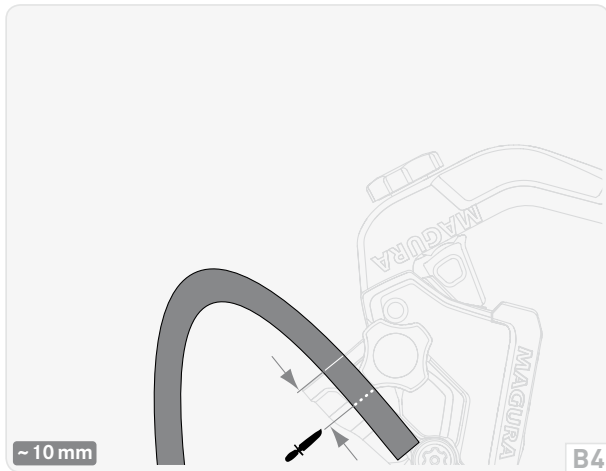
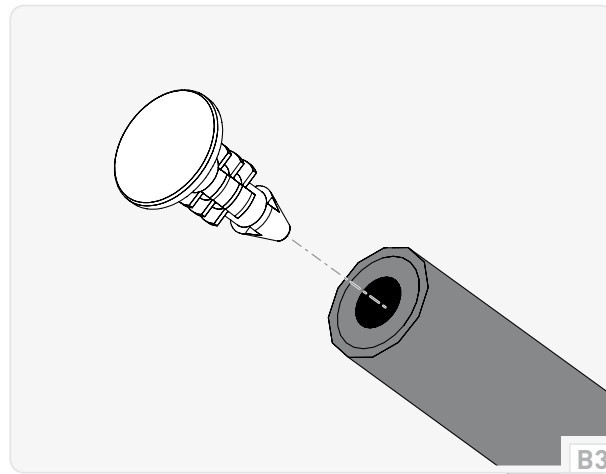
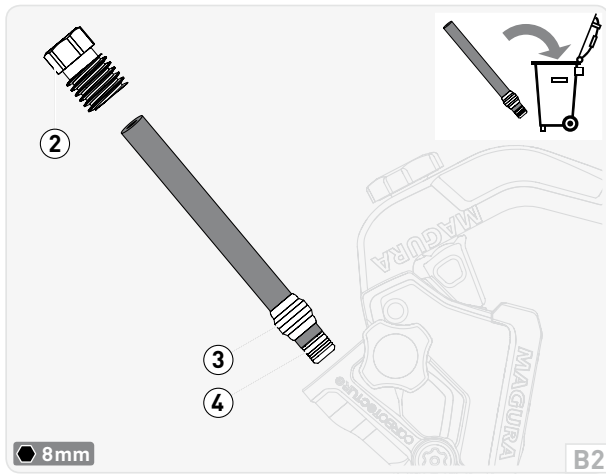

DIAGRAMS

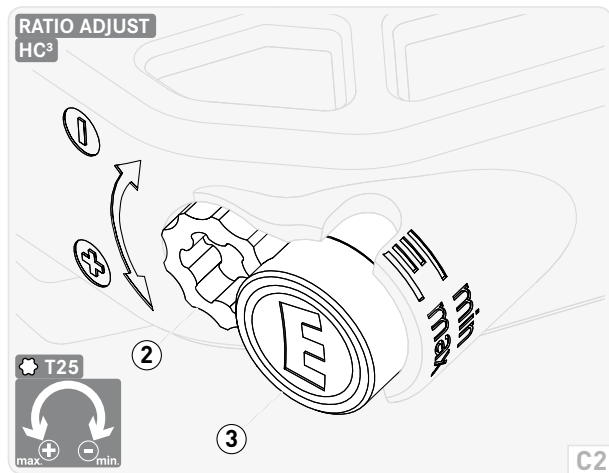
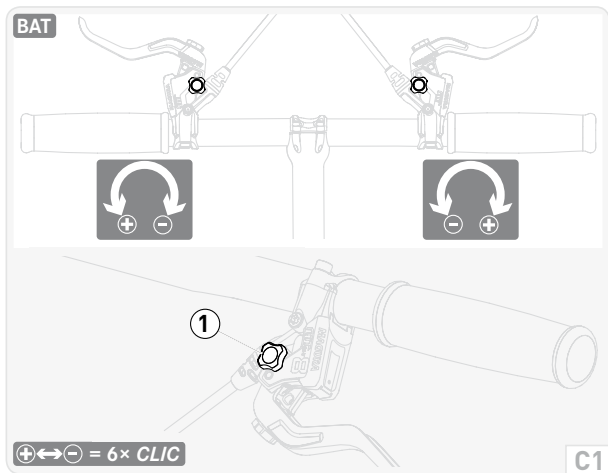
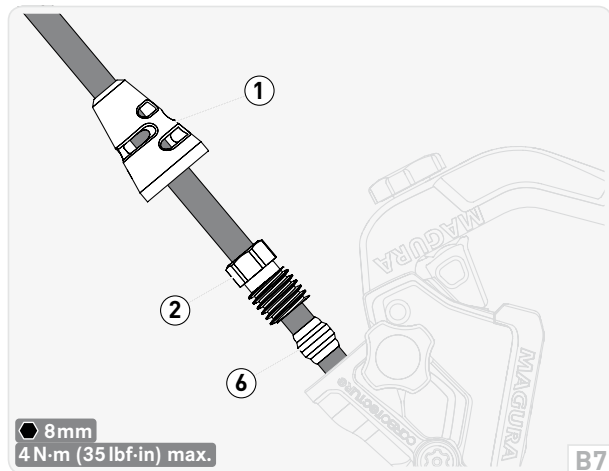
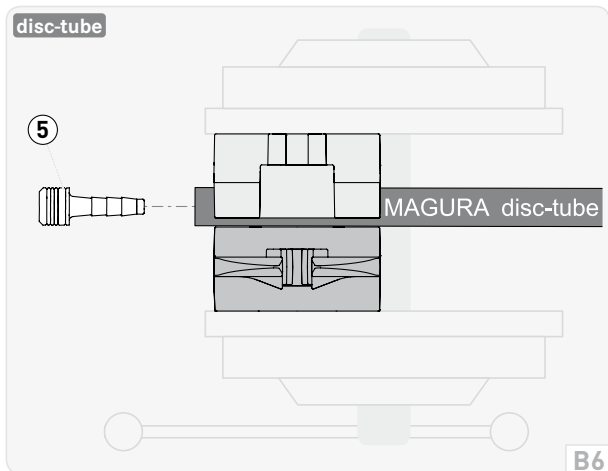

DIAGRAMS

REACH ADJUST

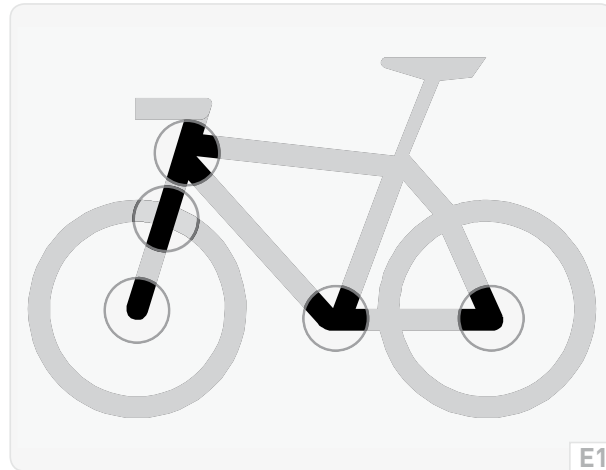
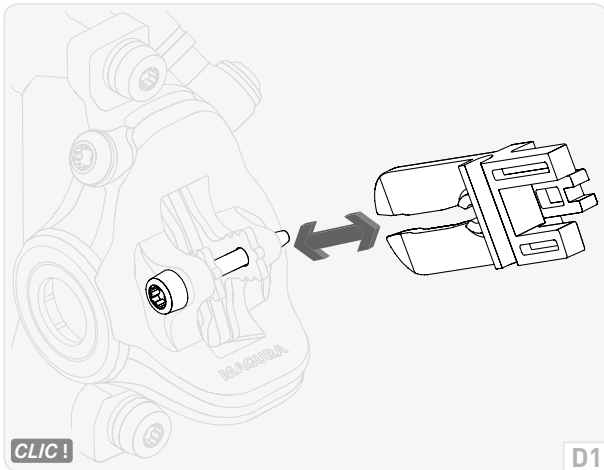
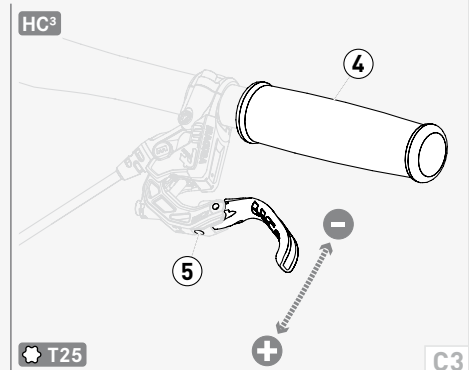
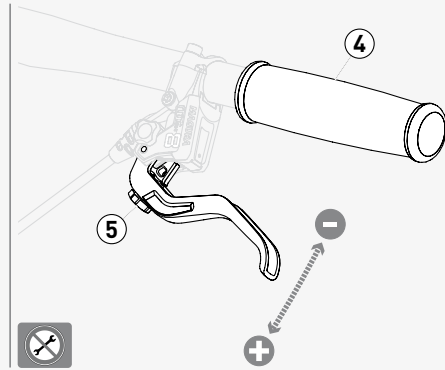
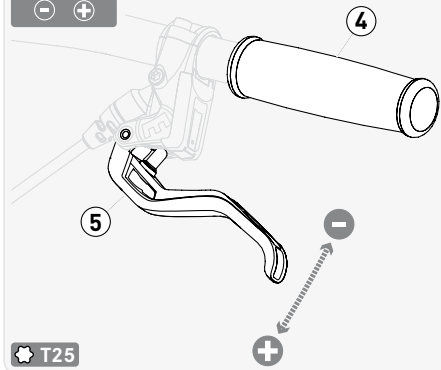

DIAGRAMS

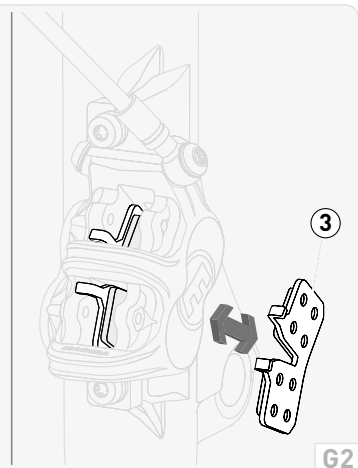
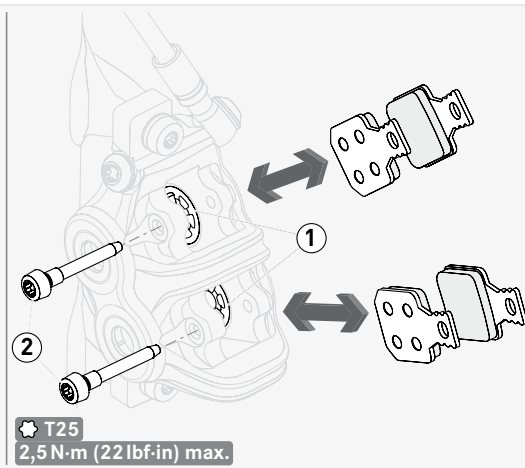
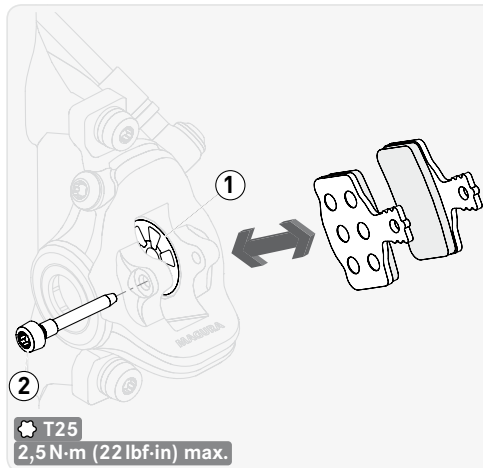
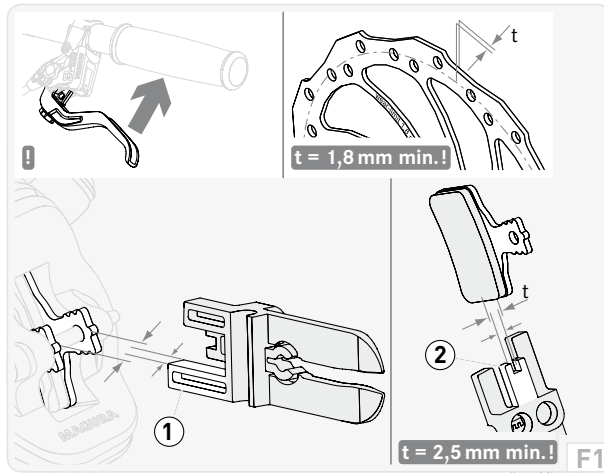

DIAGRAMS

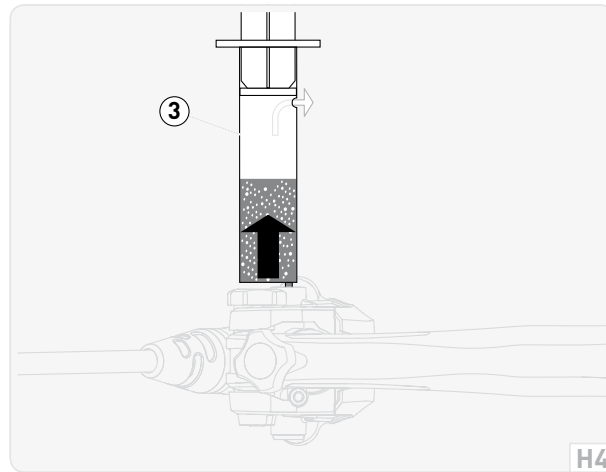
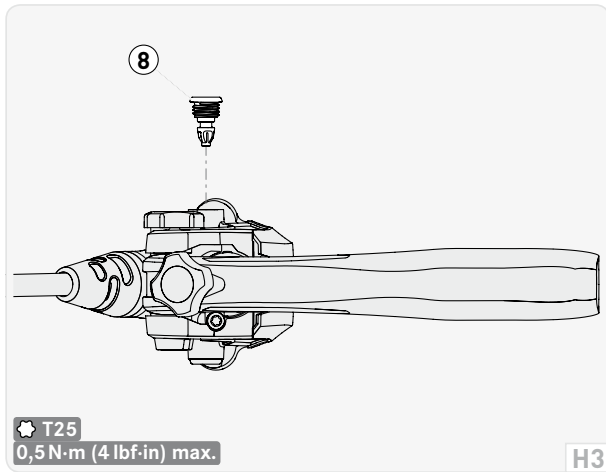
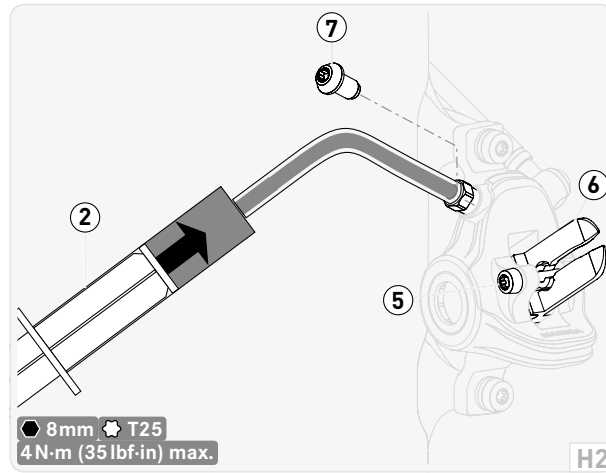
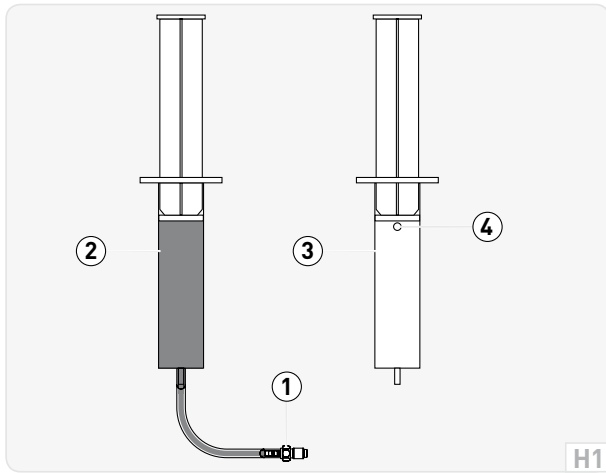

DIAGRAMS

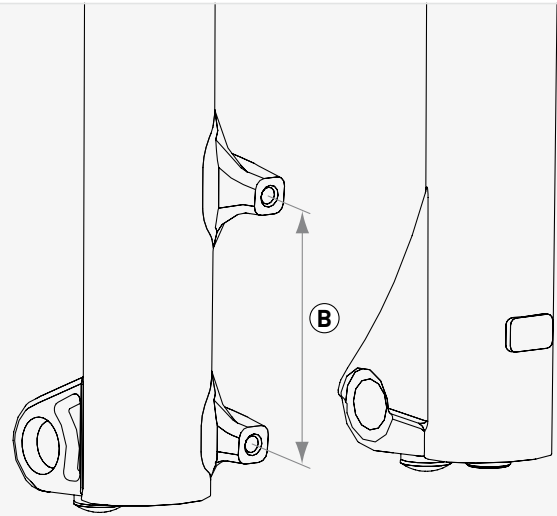
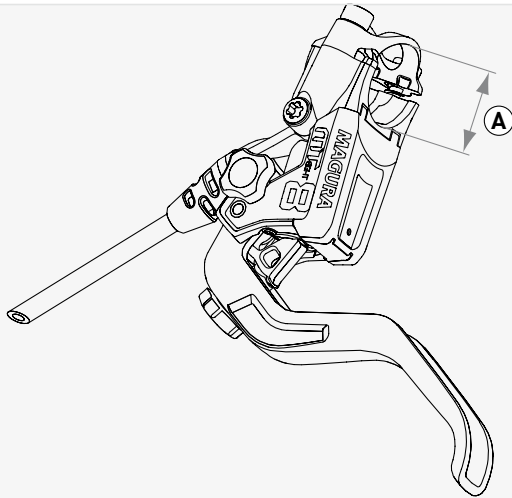

QuickMount Adapter – IS2000 Standard

QuickMount Adapter – PostMount Standard

↑
UP

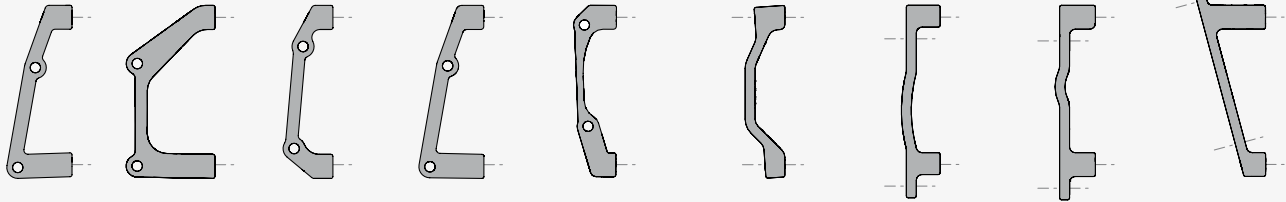

QM5 ISF-203

QM9 ISR-203

QM12 ISF-180
ISR-160

QM41 ISR-180

QM43 ISF-160

QM40 PM5-160
PM6-180

QM28 PM5-180

QM42 PM6-203

QM26 PM7-203

TD

PREFACE

Congratulations – you have purchased a powerful, low-maintenance MAGURA MT disc brake of the latest generation – developed in Germany.

This owner's manual is an integral part of your MAGURA product and gives you details of the required tools, correct installation, safe use, maintenance and setup options.

Please read this manual carefully before you install or use your MAGURA product. Always observe and follow all instructions on installation, use and maintenance provided in this manual and in instructions by third-party manufacturers whose products you use on your bicycle.

Remember that the mechanic who installs your MAGURA product is responsible for the suitability and compatibility of all the components technically linked to your MAGURA product.

▲ WARNING Failure to observe the instructions in this manual can lead to serious or fatal accidents.

You can find the figures that this manual refers to in the folder in the graphic section.

The figures in this manual may differ slightly from your MAGURA product, however, the required steps are the same for all types and variants – if not stated to the contrary.

Please note that the braking characteristics of your bicycle may be changed by installation of the new brake. Familiarize yourself with any changes in the braking characteristics of your bicycle during the first few rides.

LEGEND

▲ WARNING ... warns you about a dangerous situation which can lead to serious or fatal injury if not avoided.

▲ CAUTION ... warns you about a dangerous situation which can lead to minor or slight injury if not avoided.

NOTICE ... warns you about the risk of material damage.

⚠ NOTICE – ENVIRONMENT ... warns you about the risk of environmental pollution.

○ ... indicates how you can avoid a dangerous situation or risk of material damage or environmental pollution.

☞ ... prompts you to perform an action.

⇒ ... shows consequences or requirements.

① ... gives you additional information or tips.

③ ... refers to the corresponding item number in a figure.

[B2] ... refers to the corresponding figure in the graphic section.

2x1 A notice with this identification refers exclusively to disc brakes with 2-piston brake calliper.

4x1 A notice with this identification refers exclusively to disc brakes with 4-piston brake calliper.

Keep this manual for other users of your MAGURA product. Make sure that each user reads, understands and observes this manual.

If you sell or give away your MAGURA product, be sure to hand over this manual to the new owner.

Visit **www.magura.com** for more tips and information on your MAGURA product. You can also exchange experiences and ask questions, etc. on the MAGURA Forum.

We wish you great success and a great ride

Your MAGURA Team

TECHNICAL SPECIFICATIONS

① Some of the features detailed are optional variants. Your MAGURA disc brake is equipped as designed by your dealer or the bicycle manufacturer.

SPECIFICATIONS

Brake type	4-PISTON (MT7, MT5 ...)	2-PISTON (MT8, MT6, MT4, MT2 ...)
Brake lever	Carbotecture SL • Carbotecture Reach Adjust ¹ • BAT ² • Ratio Adjust ³ (HC ³) 1-finger (HC ³) • 2-finger • 4-finger • ball head	
Brake hose	MAGURA <i>Disc Tube</i> • MAGURA (MT2) RHR ⁴ • straight	
Brake calliper	4-piston	2-piston
Brake pads per brake calliper	4 • 2x double pad	2
Disc brake rotor	6-hole (IS) • Centerlock™ ⁵ • BionX® • Rohloff®	
Brake fluid	MAGURA <i>Royal Blood</i> (mineral oil)	
Applications	<ul style="list-style-type: none"> • S-Pedelec⁶ • Pedelec⁶ • Cargo bike • Downhill • Marathon • XC Race • XC • Enduro • AllMountain • Trekking • City 	<ul style="list-style-type: none"> • Pedelec⁶ • Marathon • XC Race • XC • Enduro • AllMountain • Trekking • City

¹ Reach Adjust – grip width adjustment.

² BAT – pressure point adjustment.

³ Ratio Adjust – braking power adjustment.

⁴ RHR – routable hose routing.

⁵ With MAGURA adapter.

⁶ Switch required.

DIMENSIONS – ASSEMBLY

Type name	MAGURA MT									
Clamping Ø brake lever (A)	22 ^{+0.3/-0.1}									
Socket distance (PM) (B)	74 ^{+0.1}									
Ø Disc brake rotor min.–max.	140–203 [5.5"–8"]									
Thickness disc brake rotor min.–max.	1.8–2.0									
Ø brake hose	5									

COMBINATIONS – DISC BRAKE ROTORS

Type / name	mm	STORM HC					STORM					STORM SL					
		160/160	180/160	180/180	203/180	203/203	160/160	180/160	180/180	203/180	203/203	160/140	160/160	180/160	180/180	203/180	203/203
Front wheel/rear wheel combination	inch	6"½"	7"½"	7"7"	8"7"	8"8"	6"½"	7"½"	7"7"	8"7"	8"8"	6"5.5"	6"6"	7"½"	7"7"	8"7"	8"8"
Total weight max. ¹	kg (lb)	150(331)	180(397)	200(441)	205(452)		130(287)	160(353)	180(397)			90(198)	105(231)	130(287)	145(320)		160(353)

¹ Maximum approved total weight = rider + bicycle + luggage + trailer

INTENDED USE

⚠ WARNING

Any use other than the intended use can lead to accidents that cause serious or fatal injury.

MAGURA disc brakes are designed and intended exclusively

- for installation on conventional touring and trekking bikes, E-Bikes* and mountain bikes with forks and frames that possess suitable mounting fixtures (IS 2000 or PostMount (PM5" etc.) socket).
- for installation on conventional – straight – touring, trekking and mountain bike handlebars.
- for use with wheels with hubs that have the corresponding mounts for the disc brake (6-hole (IS), Centerlock™ (with MAGURA adapter), Bionics®, Rohloff®).
- for the specified application – see **SPECIFICATIONS**, page 13.

MAGURA MT disc brakes must never be combined and used with components (brake lever, brake body, etc.) of MAGURA HS rim brakes!

The restriction of the allowable total weight of MAGURA MT disc brakes is subject exclusively to the selected diameter of the disc brake rotors or the combination on the front and rear wheel – see

COMBINATIONS – DISC BRAKE ROTORS, page 13.

* Taking account of relevant statutory regulations.

BASIC SAFETY INSTRUCTIONS

Always remember that riding a bicycle entails risk both for the rider and other road users, and for the bicycle and its components. Despite the use of safety gear and complete safety equipment, accidents that cause serious or fatal injury can occur.

Always use your common sense and avoid any unreasonable actions!

Installation & Maintenance

⚠ WARNING

Danger of accident due to damaged brake caused by incorrect or impermissible installation work.

- ⊙ Never overestimate your technical capabilities. Commission a specialist workshop for bicycles or an authorized MAGURA service centre with all installation and maintenance work. This is the only way to ensure that work is conducted in a professional manner.
- ⊙ Never carry out any work or make any changes (e.g. disassembly, grinding/painting etc.) to your MAGURA product that are not specifically permitted and described in the owner's manual.
- ⊙ Always observe all min./max. values stated – see **TECHNICAL SPECIFICATIONS**, page 13.
- ⊙ For assembly steps that require a specific tightening torque for a screw union, always use a torque wrench set up for the required torque.
- ⊙ Always maintain your bicycle in technically perfect working order.

Danger of accident due to improper accessories.

- ⊙ Use only MAGURA original parts.
- ⊙ Use only original MAGURA disc brake rotors, brake pads, QM-adapter and screws and also use MAGURA *Royal Blood* (mineral oil) to bleed and fill the MAGURA.
- ⊙ Never use DOT brake fluid.

On the Road

WARNING

Danger of accident due to component failure.

- Before each ride, make sure that the quick release or screw system on your wheels is fitted correctly and that your wheels will not work loose.
- Before each trip, make sure your wheels move freely and do not contact the brake pads at any point.
- Before each ride, make sure that the handlebar and stem are correctly fitted and will not twist.
- Before each ride, make sure that your brakes operate correctly – the pressure point must be clearly perceptible and does not change when the brake lever is pulled.
- Before each trip, make sure that your brakes are not damaged in any way, including with the brake lever pulled (e.g. traces of oil, cracks, etc.).
- Before each ride, make sure that the disc brake rotors and the brake pads have not reached their wear limits and are free from lubricating substances (oil, grease, silicone, wax, etc.). Never use brake pads contaminated with oil or grease – not even after attempting to clean them.
- After each crash, check your brake for damage and make sure it operates correctly.
- Never use your brake if damage (e.g. traces of oil, cracks, etc.) is visible, you can hear unusual noises or if you have any doubts about its integrity. In this case, have your brake checked in a specialist bicycle workshop or directly by MAGURA Service.

Danger of accident due to improper behaviour or improper equipment during riding.

- Always match your speed to the current road, weather conditions and the total weight. Particularly in wet conditions and a high total weight (e.g. trailers), your braking distance will be significantly increased – always

SAFETY

ride cautiously and be ready to brake.

- Always use the front and rear wheel brakes simultaneously.
- Always observe the traffic regulations in the country where you are riding (lighting, reflectors, etc.).
- When riding, always wear a high quality (e.g. ANSI certified), undamaged cycling helmet and clothing that fits snugly but does not impair your actions.
- Only ride your bicycle if you are in good physical condition and your bicycle and all of its components are in perfect working order.

Transport & Storage

WARNING

Danger of accident due to damaged components.

- Always place the transport device between the brake pads when the wheel is removed – do not pull the brake lever if the transport device is not in position.
- Make sure that brake hoses cannot be kinked when you pack your bicycle.
- Do not store your MAGURA brake at below -15°C (5°F) or above 55°C (131°F) or above 55°C (131°F).

- ① It is not necessary to drain your MAGURA brake before transporting it by air.

Protection of the environment

NOTICE – ENVIRONMENT

Dispose of used lubricants and oil correctly and in accordance with the legal requirements – never discard them in the sewage system or in the ground.

INSTALLATION

COMBINATIONS – QM-ADAPTER

Ø of disc brake rotor			140 mm (5.5")	160 mm (6")	180 mm (7")	203 mm (8")
Standard mounting socket	Fork	IS 2000 (ISF)	–	QM43 (2700 518)	QM12 (0722 426)	QM5 (0722 321)
		PM6"	–	Direct installation	QM40 (2700 515)	QM42 (2700 517)
		PM7"	–	–	Direct installation	QM26 (0724 131)
		PM8"	–	–	Direct installation	–
Standard mounting socket [TD]	Frame rear triangle	IS 2000 (ISR)	–	QM12 (0722 426)	QM41 (2700 516)	QM9 (0722 325)
		PM5"	Direct installation	QM40 (2700 515)	QM28 (0724 496)	–
		PM6"	–	Direct installation	QM40 (2700 515)	QM42 (2700 517)
		PM7"	–	–	Direct installation	QM26 (0724 131)
		PM8"	–	–	–	Direct installation

INSTALLING THE BRAKE

Important – see **BASIC SAFETY INSTRUCTIONS**, page 14!

▲ CAUTION Danger of injury on sharp or hot disc brake rotor.

- Install the quick release skewer of the front wheel on the right.
- ① The following assembly steps always refer to the front wheel brake, but they are identical for the rear wheel brake unless otherwise specified.

Installing the adapter

- ☞ Make sure that the contact surfaces of the socket are milled smooth, free from burrs and paint residues and are coated with corrosion protection.
- ☞ Make sure that your MAGURA QM adapter fits the disc brake rotor (diameter) and standard mounting socket – see table.
- ☞ Make sure that the retaining screws are always coated with fresh screwlock (medium strength) before installation.
- ① MAGURA QM adapters are generally fitted with an arrow – when installed the arrow must point upwards (UP). The label on the QM adapter must always be readable from the left side of your bicycle. The overview shows the correct installation position of the QM adapter. [TD]

① The MAGURA QM adapter **QM40** is screwed directly to the PM sockets with the brake calliper [A2] – see **Installing brake calliper**, page 17 – the following installation step is therefore not required for the **QM40**.

- ☞ Tighten retaining screws (1) with tightening torque of **6 N·m (53 lbf·in)**. [A1]
- ⇒ The arrow on the QM adapter points upwards – the label can be read from the left.

Installing brake lever

- ① Before installing your brake decide which brake lever (right or left) you want to allocate to your front wheel or rear wheel brake.
- ☞ Make sure that the size of your handlebar (brake lever clamp diameter) fits your brake lever – see **TECHNICAL SPECIFICATIONS**, page 13.
- ☞ Push the brake lever onto the handlebar.
- ⇒ Arrows (thick end of the clamp) point upwards! [A3]
- ☞ First tighten the upper clamping screw (2), then the lower one (3) with tightening torque of **4 N·m (35 lbf·in)**.
- ⇒ The clamping screw is in contact at the top, there is a gap at the bottom!

- ① The brake lever can be rotated by hand when forced. It is advantageous if the brake lever can rotate in the event of a fall. This reduces the danger of irreparable damage to brake lever or handlebar.
- ① If you reverse the position (right or left) of your brake levers, you can easily change the position of the rotating dial (BAT) or cover without tools so they are still on top. [A4]
 - ☞ Press the locking disc (4), rotate 90° and remove it with the clamp spring (5).
 - ☞ Pull and hold brake lever lightly.
 - ☞ Pull out rotating dial (BAT) (6) or cover (7) and replace from above.
 - ☞ Position clamp spring with locking disc, press and rotate 90°.

Installing disc brake rotor

- ☞ Place disc brake rotor on the axle flange.
 - ⇒ The direction arrows point in the direction of forward movement. [A5]
- ☞ Make sure that all retaining screws are coated with fresh screwlock (medium strength).
- ☞ Screw in retaining screws 2–3 threads.
- ☞ Turn disc brake rotor clockwise to the stop.
- ☞ Tighten retaining screws crosswise with tightening torque of **4 N·m (35 lbf·in)**. [A5]
- ① To install a Centerlock™ hub, the MAGURA *Centerlock adapter* is required.
 - ☞ Thoroughly degrease the disc brake rotor using brake cleaner or spirits.

INSTALLATION

Installing brake calliper

- ☞ Make sure that the retaining screws are always coated with fresh screwlock (medium strength) before installation.
- ☞ Install wheel with mounted disc brake rotor – make sure that the hub is correctly seated between the dropouts.
- ☞ If applicable, pull the transport device out of the brake calliper. [D1]
- ☞ Carefully press brake pads apart to the stop with transport device or a wide screwdriver.
- ☞ Make sure that the brake hose is optimally positioned – see **Aligning & laying out the brake hose**, page 18.
- ☞ Carefully guide the brake calliper over the disc brake rotor and place on PM socket or QM adapter. [A6]
- ☞ Screw in retaining screws (8).
- ☞ **MAGURA QM40**: carefully guide brake calliper over disc brake rotor and place on PM socket with **QM40**. [A2]
- ☞ Make sure that the convex (9) and concave discs (10) are correctly positioned.
- ☞ Screw in retaining screws top (M6×35) (11) and bottom (M6×33) (12).
 - ⇒ The brake calliper can still be moved slightly but only wobbles slightly.
- ☞ Pull and release the brake lever several times.
 - ⇒ Pressure point is clearly noticeable and does not change.
- ☞ Pull and hold brake lever.
- ☞ Tighten retaining screws alternately and in stages up to tightening torque of **6 N·m (53 lbf·in)**. [A6] [A2]
- ☞ Check that the disc brake rotor runs freely – if necessary, loosen the retaining screws and repeat the last steps.
- ☞ Check position (height) of brake calliper – use washers if necessary.

Aligning & laying out the brake hose

⚠ WARNING

Danger of accident due to restricted or blocked steering movement because brake hose is too short or too long.

- ⊙ Make sure that there is full steering movement in both directions.
- ⊙ Make sure that all suspension can function freely.
- ⊙ Keep the length of the brake hose as short as possible and as long as necessary.

Danger of accident due to brake failure caused by faulty installation.

- ⊙ Make sure that the brake hose cannot be crushed, jammed or stretched in any position (steering, suspension).
- ⊙ Make sure that the brake hose remains at least 20mm from the disc brake rotors in all positions (steering, suspension).

① MAGURA's routable hose routing (RHR) makes it easy to route the brake hose correctly. [A7]

- ↻ Unscrew the screw plug (13) slightly – max. 30° – and hold it.
- ↻ Press the hose connection (14) towards lower leg or rear triangle stay.
- ↻ Tighten screw plug with tightening torque of **3 N·m (27 lbf·in)**. [A7]
- ↻ Fix the brake hose along the optimum position at the specified or suitable points.

① When installing the brake hose for the rear wheel brake use the practical MAGURA hose holder – available in different models.

① If it is necessary to route the brake hose of your rear-wheel brake inside the bike frame, you must open the brake system at the brake lever – see **Shortening brake hose**, page 18. If necessary, shorten the brake hose for this.

A thin wire may be helpful for inserting through the bike frame. Thread it through the openings of the frame in the opposite direction and attach it to the end of the brake hose with adhesive tape. However, do not insert the wire into the brake hose – oil loss!

Use the MAGURA hose plug. [B3]

Carefully pulling with the wire and pushing the brake hose at the same time will make it easier to find the outlet.

Shortening brake hose

The brake hose may have to be disconnected from the brake lever for the following steps.

NOTICE

Loss of oil when the brake hose is removed/disconnected.

- ⊙ Do not actuate the brake lever if the brake hose is disconnected.
- ⊙ Handle the open brake hose carefully – do not shake it, knock it or hit it.
- ⊙ Have clean, absorbent and lint-free cloths ready – wipe any leaking oil away immediately.

Unusable brake hose – because it is too short.

- ⊙ Before shortening the brake hose make sure that the handlebar and stem are in their final position and do not need to be raised, extended or adjusted in any way.
- ⊙ Make sure that there is full steering movement in both directions.
- ⊙ Make sure that all suspension can function freely.
- ⊙ If required, allow a little longer at first – you can always shorten it a bit more but you can't extend it!
- ⊙ Do not cut the brake hose with side cutters or a saw.
- ⊙ Cut the brake hose with a suitable wire cutter (e.g. MAGURA *wire cutter*) or a sharp knife only.

- ☞ Remove the wheel.
- ☞ Carefully press brake pads apart to the stop with transport device or a wide screwdriver.
- ☞ Loosen the bottom clamping screw (3) [A3].
- ☞ Turn the brake lever so it is pointing vertically upwards [B1].
- ☞ Tighten the bottom clamping screw with tightening torque of **4 N·m (35 lbf·in)**.
- ☞ Push the hose cover (1) upwards [B1].
- ⓘ If sufficient hose length is available, the ideal solution is to cut off the hose **before** loosening the sleeve nut. This prevents the entry of air into the brake lever.
- ☞ Make sure that there is sufficient hose available.

NOTICE Oil loss due to hose springing back.

- Hold hose ends tightly against the interface.
- ☞ Cut off the brake hose approx. 10–15 cm before the sleeve nut. [B1]
- ☞ Unscrew the sleeve nut (2) with olive (3), support sleeve (4) and remaining hose from the brake lever [B2].
- ⇒ Do not use old olives and support sleeves again!
- ⇒ Now install the brake hose inside the bike frame, if applicable – see **Aligning & laying out the brake hose**, page 18.
- ☞ Hold the end of the brake hose to the brake lever [B4].

NOTICE Unusable brake hose – because it is too short.

- Calculate the insertion depth (~10 mm) of the brake hose in the brake lever [B4].
- ☞ Mark the cut on the brake hose.
- ☞ Cut the hose at right angles.
- ☞ Place the sleeve nut (2) and new olive (6) on the brake hose [B7].
- ☞ **MAGURA disc-tube**: fasten the brake hose between two transport devices (pliers, vice etc.). [B5] [B6]
- Drive new support sleeve (5) into the brake hose to the stop. [B6]

INSTALLATION

- ⓘ The support sleeve must be used exclusively with MAGURA brake hoses labelled with the words **MAGURA disc-tube**. Note the identification of your brake hose!
- ☞ Insert the brake hose into the brake lever to the stop. Hold the brake hose to the stop until you finish tightening the sleeve nut.
- ☞ First screw the sleeve nut handtight in the brake lever, then tighten with tightening torque of **4 N·m (35 lbf·in)** [B7].
- ⇒ The thread of the sleeve nut is no longer visible.
- ☞ Pull the brake hose to ensure that it is tight.
- ☞ Remove any oil residues thoroughly.
- ☞ Install wheel with mounted disc brake rotor or insert transport device. [D1]
- ☞ Pull and hold the brake lever several times and check: No oil is leaking from any part of the brake system. Pressure point is clearly noticeable and does not change.
- ⓘ In general it is not necessary to bleed the brake hose after shortening it. However, if air enters the brake system and there is no stable pressure point, you must bleed your brake – see **BLEEDING AND FILLING BRAKE**, page 24.
- ☞ Push hose cover (1) on the sleeve nut.
- ☞ Loosen the bottom clamping screw (3) [A3].
- ☞ Rotate brake lever to final position.
- ☞ Tighten the bottom clamping screw with tightening torque of **4 N·m (35 lbf·in)**.

Setting the pressure point

① You can see that the pressure point of your brake lever (6 positions) can be adjusted by the rotating dial (BAT) ① [C1]. Brake levers that do not have the rotating dial position the pressure point automatically!

⚠ **WARNING** Danger of accident due to brake failure.

- ⦿ Before setting the pressure point, make sure that the wear limits of the brake pads and disc brake rotors have not been reached.
- ① At the right brake lever: **clockwise** in "Plus" (+) direction.
At the left brake lever: **counterclockwise** in "Plus" (+) direction.
- ↻ Rotate rotating dial (BAT) in "Plus" (+) direction. [C1]
- ⇒ Pressure point on the brake lever acts at an earlier point.
- ⇒ Brake lever moves closer to the handlebar.
- ↻ Adjusting the brake levers if required.

Adjusting the brake levers

① You can adjust the position of the brake lever (Reach Adjust – grip width) Adjust your MAGURA MT as required. This adjustment does not affect the pressure point of the brake!

⚠ **WARNING** Danger of accident due to brake failure.

- ⦿ Make sure that the brake lever when tightened is at least 20 mm from the handlebar ④ [C3].
- ↻ Screw the adjusting screw/rotating dial ⑤ (-) or in (+).
- ⇒ Brake lever moves closer to or further away from the handlebar.

HC³ – adjust braking power

① You can adjust the braking power at the HC³ brake lever (Ratio Adjust). Adjust your MAGURA MT as required – manual force, lever path, pressure point, controllability.

⚠ **WARNING** Danger of accident due to changing the controllability of the braking power.

- ⦿ Make yourself familiar with the changed braking action of the MAGURA MT away from road traffic.
- ⚠ **WARNING** Danger of accident due to brake failure.
- ⦿ Make sure that the brake lever when tightened is at least 20 mm from the handlebar ④ [C3].
- ↻ Rotate adjusting screw ② in "Plus" (+) direction. [C2]
- ⇒ Indicator ③ moves in "max." direction.
- ⇒ Brake lever path increases.
- ⇒ Required manual force decreases – with the same braking power.
- ⇒ Pressure point on the brake lever acts at a later point.
- ⇒ Pressure point on brake lever feels softer.
- ↻ Rotate adjusting screw ② in "Minus" (-) direction. [C2]
- ⇒ Indicator ③ moves in "min." direction.
- ⇒ Brake lever path decreases.
- ⇒ Required manual force increases – with the same braking power.
- ⇒ Pressure point on the brake lever acts at an earlier point.
- ⇒ Pressure point on brake lever feels harder.
- ↻ Adjusting the brake lever if required.

- ① Take some time to familiarize yourself with your new MAGURA brake – preferably away from traffic.

PRIOR TO FIRST RIDE

- ☞ Thoroughly degrease the disc brake rotor using brake cleaner or spirits.

⚠ WARNING

Danger of accident due to ill-considered operation of the brake system.

- Make yourself familiar with the arrangement of the brake levers.
As a rule, the brake lever for the front wheel brake is fitted on the left side – have the arrangement changed if required.
- Make yourself familiar with the higher braking action of MAGURA MT away from road traffic.

Bedding-in brake pads

- ① New brake pads develop their final braking force during the bedding-in phase.
- ☞ Accelerate bicycle to about 30 km/h (20 mph).
- ☞ Brake bicycle to a stop.
- ☞ Repeat 30 to 50 times.
- ⇒ The brake pads and disc brake rotors are run in and offer optimum braking power.

BEFORE EACH RIDE

Important – see **BASIC SAFETY INSTRUCTIONS**, page 14!

⚠ WARNING

Danger of accident due to brake failure.

- Pull and hold the brake lever and check:
No oil is leaking from any part of the brake system.
Pressure point is clearly noticeable and does not change.
- Make sure that the brake pads and disc brake rotors are intact and free from grease/oil.

DURING TRANSPORT

Important – see **BASIC SAFETY INSTRUCTIONS**, page 14!

NOTICE

Loss of oil and irreparable damage to the braking system.

- Never pull the brake lever when the wheel is removed if the transport devices are not inserted.
 - Always use transport devices for transport with wheels removed.
-
- ☞ Insert transport device between the brake pads until it locks. [D1]
Use two transport devices per brake calliper with 4-piston brake callipers!
 - ① With dual brake pads without brake pad locking screw the transport device does not lock but is only jammed between the pads.

REGULAR

- ① How frequently you need to maintain your MAGURA product depends on how often you use it, but also on weather conditions. Perform the following maintenance steps more frequently if you use your bicycle in extreme conditions (rain, dirt, high mileage, etc.).

If you are a frequent user, also consider the fact that this exposes your MAGURA product to more wear and thus requires more frequent maintenance intervals and checks.

NOTICE Corrosion and material damage due to water penetration.

- Never use a pressure or steam cleaner to clean your bicycle – the seals on your bicycle components are not built to withstand this pressure.
- You should even exercise care if you use a water hose. Never point the water jet directly at seal areas [E1].
- ☞ Clean the brake and disc brake rotors with water, detergent and a brush.
- ☞ Thoroughly degrease the disc brake rotor using brake cleaner or spirits.
- ☞ Inspect brake pads and disc brake rotors for wear and damage (cracks, deformation, etc.) at regular intervals.
 - see **CHECKING WEAR ON BRAKE PADS AND DISC BRAKE ROTORS**, page 22,
 - see **CHANGING BRAKE PADS**, page 23,
 - see **Installing disc brake rotor**, page 17.
- ☞ Pull and hold the brake lever several times and check:
No oil is leaking from any part of the brake system.
Pressure point is clearly noticeable and does not change.
Bleed brake if necessary – see **BLEEDING AND FILLING BRAKE**, page 24.
- ☞ Check and if necessary tighten screws on brake lever [A3], mounting socket [A1], brake calliper [A2] [A6], disc brake rotor [A5] and hose connection (RHR) [A7] at regular intervals.

CHECKING WEAR ON BRAKE PADS AND DISC BRAKE ROTORS

- ① The MAGURA brake pad is considered worn if the thickness t (pad + pad carrier plate) is less than 2.5 mm at any point.
The MAGURA disc brake rotor is considered worn if the thickness t is less than 1.8 mm at any point.

... with wheel installed and brake pads mounted:

- ☞ Make sure that the thickness t of the disc brake rotor is not less than 1.8 mm at any point.
- ☞ Pull and hold brake lever.
- ☞ Make sure that the wear gauge⁽¹⁾ of the transport device fits between the pad carrier plates [F1].
- ⇒ Brake pads have not reached the wear limit.

... with brake pads removed:

- ☞ Check brake pads for damage (cracks, etc.).
- ☞ Make sure that the brake pads do not fit into the wear gauge⁽²⁾ of the transport device at any position [F1].
- ⇒ Brake pads have not reached the wear limit.
- ☞ Replace damaged or worn brake pads or disc brake rotors with new parts.

CHANGING BRAKE PADS

⚠ WARNING

Danger of accident due to brake failure caused by faulty installation.

- Use only original MAGURA brake pads.
- Always use new brake pads if new disc brake rotors are installed.
- Never use brake pads contaminated with oil or grease – not even after attempting to clean them.
- Make sure that the brake pad locking screw is always coated with fresh screwlock (medium strength).

NOTICE

Loss of oil and irreparable damage to the braking system.

- Never pull the brake lever when the wheel and brake pads have been removed.

Loss of insurance protection with S-Pedelecs (E-Bikes up to 45 km/h) that require insurance.

- Use original MAGURA brake pads and MAGURA disc brake rotors exclusively.
- Never replace dual brake pads with single brake pads.
- Never change the size of the disc brake rotors.

- ☞ Remove the wheel.
- ☞ Carefully press brake pads apart to the stop with transport device or a wide screwdriver.
- ↳ All brake pistons (1) are in fully extended position [G2].
- ☞ Screw brake pad locking screw (2) out.
- ☞ Remove brake pads one by one up or down (dual brake pads (3) without brake pad locking screw) from the brake calliper.
- ☞ Clean inside of brake caliper (compressed air, small brush, cloth, etc.) if applicable use *MAGURA brake cleaner*.

MAINTENANCE

- ☞ Install brake pads up or down (dual brake pads (3) without brake pad locking screw) in the brake caliper.
 - ↳ Pad carrier plate points to the magnetic brake piston, brake pad to the disc brake rotor.
 - ☞ Insert the brake pad locking screw (2) through the brake calliper and eyes (4) of the brake pads and tighten with tightening torque of **2.5 N·m (22 lbf·in) [G1]**.
 - ☞ Install wheel with mounted disc brake rotor or insert transport device. [D1]
 - ☞ Actuate the brake lever several times.
 - ↳ Brake pads are aligned.
 - ☞ Make sure that the disc brake rotor runs between the brake pads without friction.
 - ☞ Align brake calliper if necessary – see *Installing brake calliper*, page 17.
- ⚠ **WARNING** Danger of accident due to brake failure.
- Pull and hold the brake lever and check: Pressure point is clearly noticeable and does not change.
 - Make sure that the brake pads and disc brake rotors are intact and free from grease/oil.
 - ☞ Set the pressure point – see *Setting the pressure point*, page 20.

BLEEDING AND FILLING BRAKE

- ① EBT (Easy Bleed Technology) makes it easy to bleed the brake.
- ① The only difference between bleeding and filling – if any – is the amount of oil required – the procedure is identical.
- ① Always fill at the brake calliper, never at the brake lever!

NOTICE

Loss of oil and irreparable damage to the braking system.

- Open the screw plugs for bleeding and filling only.
 - Use **MAGURA Royal Blood** (mineral oil) exclusively for bleeding and filling – never DOT brake fluid.
-
- ① Because **MAGURA Royal Blood** does not age, it is not necessary to bleed or refill your **MAGURA** brake regularly. Do this only if one of the following reasons requires it:
 - ⇒ The brake does not respond immediately when the brake lever is actuated.
 - ⇒ Pressure point is not clearly defined, it is spongy or does not remain constant.
 - ⇒ After changing the brake hose.
 - ① To bleed or fill your **MAGURA** brake you will need the **MAGURA Service Kit** or the **MAGURA Pro Bleed Kit** – available from dealers.
 - ☞ Insert barbed fitting (1) tightly into the filling line by hand [H1].
 - ☞ Fill filling syringe (2) with **MAGURA Royal Blood**.
 - ☞ Make sure that there is no air in the filling syringe and filling line.
 - ☞ Pull the piston of the bleeding syringe (3) out as far as the stop.
 - ☞ Piston base is above bleed bore (4).
 - ① If your bleeding syringe does not have the bleed bore, you can make it yourself – the easiest way is to use a Ø 2 mm drill bit for wood or metal.

- ① At the right brake lever: **clockwise** in “Plus” (+) direction. At the left brake lever: **counterclockwise** in “Plus” (+) direction.
 - ☞ Rotate rotating dial (BAT) (1) to the stop in the “Plus” (+) direction [C1].
 - ☞ Remove the wheel.
 - ☞ Carefully press brake pads apart to the stop with transport device or a wide screwdriver.
 - ⇒ All brake pistons (1) are in fully extended position [G2].
 - ☞ Removing brake pads – see **CHANGING BRAKE PADS**, page 23.
 - ☞ Screw in brake pad locking screw (5) [H2].
 - ☞ Insert transport device (6) between the brake pistons from below until it locks.
 - Use two transport devices per brake calliper with 4-piston brake callipers and fasten them with a rubber ring or similar if necessary!
 - ☞ Align brake caliper vertically.
- ① If your assembly stand makes it impossible to align the brake calliper vertically, you will have to unscrew it to bleed it. We always recommend this procedure, because it is better to hold the brake calliper above the level of the brake lever on completion of the bleeding process and before removing the filling syringe to prevent oil loss.
 - ☞ Unscrew the screw plug (7) from the filler hole of the brake calliper.
 - ☞ Screw the barbed fitting of the filling syringe (2) into the filler hole and tighten with tightening torque of **4 N·m (35 lbf·in)** [H2].
 - ☞ Loosen the bottom clamping screw (3) [A3].
 - ☞ Turn the brake lever so it is pointing horizontally forwards or backwards [H3].
 - ☞ Tighten the bottom clamping screw with tightening torque of **4 N·m (35 lbf·in)**.
 - ☞ Unscrew the EBT screw (8) from the bleed hole [H3].

MAINTENANCE

- ☞ Insert the bleeding syringe [3] tightly into the bleed hole [H4].
- ☞ Press MAGURA *Royal Blood* slowly out of the filling syringe [2] through the brake system – tap lightly on the brake cylinder and brake lever during this process.
- ☞ Flick the brake lever 2–3 times.
- ☞ This dislodges air bubbles and they rise into the bleed syringe [3] [H4].
- ☞ Continue the process until you cannot see any more air bubbles.
- ☞ The brake system has been bled.

NOTICE Oil loss when removing the bleed syringe.

- Have a clean cloth at hand.
- Hold the bleed bore closed before and after pulling off of the bleeding syringe.
- Hold the bleeding syringe with its point upwards after pulling off, and push in the plunger until just beyond the bleed bore.
- ☞ Pull the bleeding syringe out of the bleed hole.
- ☞ Press a little MAGURA *Royal Blood* slowly out of the filling syringe [2] through the brake system until the bleed hole is just filled.
- ☞ Screw the EBT screw [8] into the bleed hole and tighten with tightening torque of **0.5 N·m (4 lbf·in)**. [H3]

NOTICE Oil loss when unscrewing the filling syringe.

- Have a clean cloth at hand.
- After unscrewing close the filler hole quickly.
- Before unscrewing, lift the brake calliper above the level of the brake lever, if possible.
- ☞ Unscrew the barbed fitting of the filling syringe [2] from the filler hole. [H2]
- ☞ Screw the screw plug quickly into the filler hole and tighten with tightening torque of **4 N·m (35 lbf·in)** [H2].
- ☞ Remove any oil residues thoroughly.

- ☞ Pull and hold the brake lever several times and check: No oil is leaking from any part of the brake system. Pressure point is clearly noticeable and does not change.
- ☞ Install brake pads – see **CHANGING BRAKE PADS**, page 23.
- ☞ Install wheel with mounted disc brake rotor or insert transport device. [D1]
- ☞ Move the brake lever into the customary position and secure – see **Installing brake lever**, page 16.
- ☞ Set the pressure point – see **Setting the pressure point**, page 20.

THE RULES

LIABILITY

Wear – including from normal use – is not covered by the liability. The liability is invalidated if the product is no longer used as intended. The intended use also includes complying with all our instructions relating to installation, operation and maintenance in this owner's manual.

The statutory liability provisions apply.

Please contact your retailer regarding the handling of any liability claims!

A liability claim can only be processed if accompanied by a purchase receipt from the retailer.

The validity of a liability claim will be significantly impaired by:

- incorrect use,
- incorrect maintenance,
- damage attributable to falling,
- use of non-genuine MAGURA spare parts,
- use of non-genuine MAGURA hydraulic fluids,
- modification to the surface (e.g. painting ...),
- modification to the structure (e.g. drilling holes ...),
- removing the serial number or rendering it illegible,
- damage in transit or loss.

WARRANTY

- ① For information about the 5-year leak-tightness warranty, refer to www.magura.com

THE RULES

We at the MAGURA company work continuously on improving our products in conjunction with ongoing technical development.

For this reason, we reserve the right to introduce modifications which differ from the illustrations and descriptions in this owner's manual.

No claims for modifications of products which have already been delivered can be derived from these circumstances.

For current information, see **www.magura.com**

Technical dimensions and weight information are subject to the corresponding usual tolerances.

This owner's manual is not allowed to be reprinted or translated, either in whole or in part, without the written approval of MAGURA.

All rights under copyright regulations are reserved.

① Unsere weltweiten Handelspartner und Service Center finden Sie unter www.magura.com

① Check out our worldwide partners and service centers at www.magura.com

Deutschland

MAGURA Bike Parts GmbH & Co. KG
Eckisstraße 6
D-72574 Bad Urach

phone +49 71 25 96 94 6-0
fax +49 71 25 96 94 6-17
info@magura.de

Asia

MAGURA Asia Limited Co.
No. 9, Industrial Park, 10th Road
Taichung City
40755 Taichung City, Taiwan

phone +886 4 2359 8555
fax +886 4 2359 99 10
info@magura.com.tw

USA

MAGURA USA
724 West Clem
62450 Olney, Illinois

phone +1 618 395-2200
fax +1 618 395-4711
magura@magurausa.com

© MAGURA 2016

All rights reserved

Printed in Germany

2 600 318 – 07-2016

Umschlag & Inhalt:

www.technische-redaktion.de